

PROPRIETARY NOTICE

NOTICE IS HEREBY GIVEN THAT THIS DOCUMENT EMBODIES A CONFIDENTIAL PROPRIETARY DESIGN OR IS PART OF A CONFIDENTIAL PROPRIETARY DESIGN ORIGINATED BY OURSELVES OR ONE OF OUR CUSTOMERS, AND ALL DESIGN, MANUFACTURING, PREPRODUCTION USE AND SALE RIGHTS REGARDING THE SAME ARE EXPRESSLY RESERVED. IT IS SUBMITTED UNDER A CONFIDENTIAL RELATIONSHIP FOR A SPECIFIC PURPOSE, AND THE RECIPIENT BY ACCEPTING THIS DRAWING AGREES NOT TO SUPPLY OR DISCLOSE ANY INFORMATION REGARDING IT TO ANY UNAUTHORIZED PERSON, OR TO INCORPORATE IN OTHER PROJECTS, ANY SPECIAL FEATURES PECULIAR TO THIS DESIGN.

REVISION HISTORY

| REV | LOC | DESCRIPTION | DATE | APP'VD |
|-----|-----|--|------------|--------|
| B0 | C8 | CHANGED THRU HOLE FROM .172 to .182" | 04/30/2009 | AWR |
| B0 | A7 | MOVED PT3 & SA1 CONNECTORS .025" FROM .221" to .246" | 04/30/2009 | AWR |
| B0 | A7 | MOVED PT4 CONNECTOR .015" FROM 2.588" TO 2.573" | 04/30/2009 | AWR |
| B0 | C7 | ADDED PUMPKIN LOGO CALLOUT | 04/30/2009 | AWR |

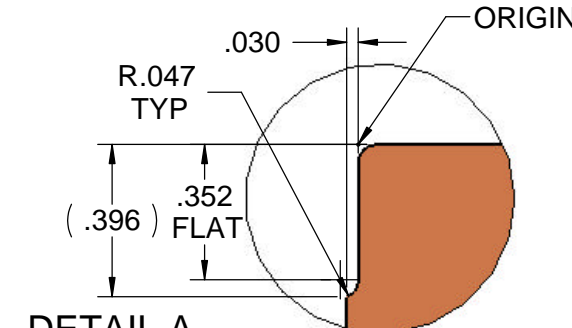
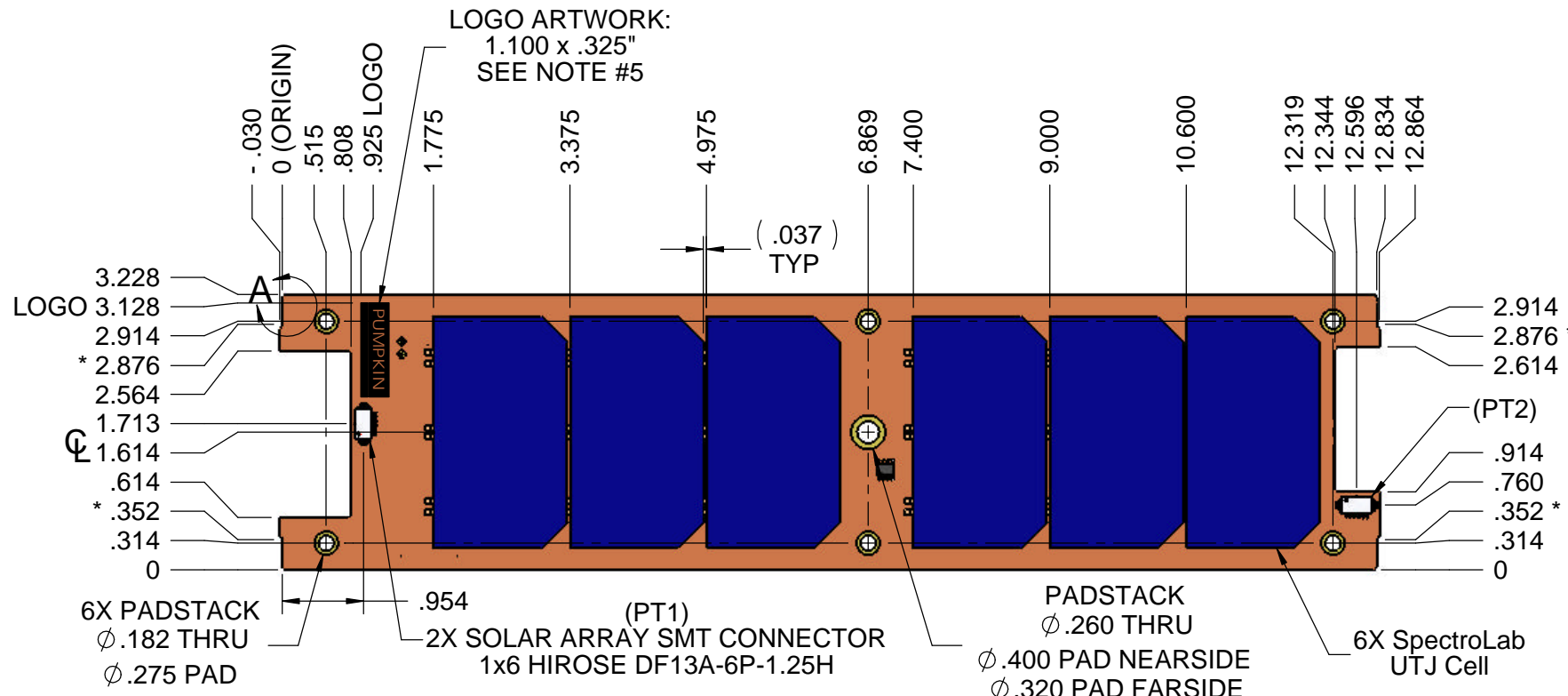

DETAIL A
SCALE 2 : 1
CORNER DETAIL
(2 PLACES)

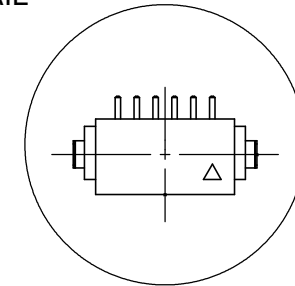

DETAIL B
SCALE 2 : 1

| SOLAR ARRAY CONNECTOR | |
|-----------------------|-------------|
| PIN # | LABEL |
| 1 | POS_OUTSIDE |
| 2 | RTN_OUTSIDE |
| 3 | TLM_OUTSIDE |
| 4 | POS_INSIDE |
| 5 | RTN_INSIDE |
| 6 | TLM_INSIDE |

- NOTES:**
- 1) ALL PLATED THRU HOLES ARE SPEC'D AFTER PLATING
 - 2) "INSIDE" REFERS TO THE SURFACE THAT FACES THE SATELLITE, AND "OUTSIDE" REFERS TO THE SURFACE THAT FACES AWAY FROM THE SATELLITE, WHEN LOADED IN THE LAUNCH SYSTEM.
 - 3) DIMENSIONS WITH AN ASTERISK (*) ARE MARKING A TANGENCY POINT.
 - 4) REFER TO SHEET #2 FOR KEEP-OUT ZONES ON THE INSIDE.
 - 5) LOGO TO APPEAR ON METAL LAYER; WITH THE TEXT IN METAL. FOR LOGO SPECIFICATIONS AND DXF FILES, CONTACT PUMPKIN.

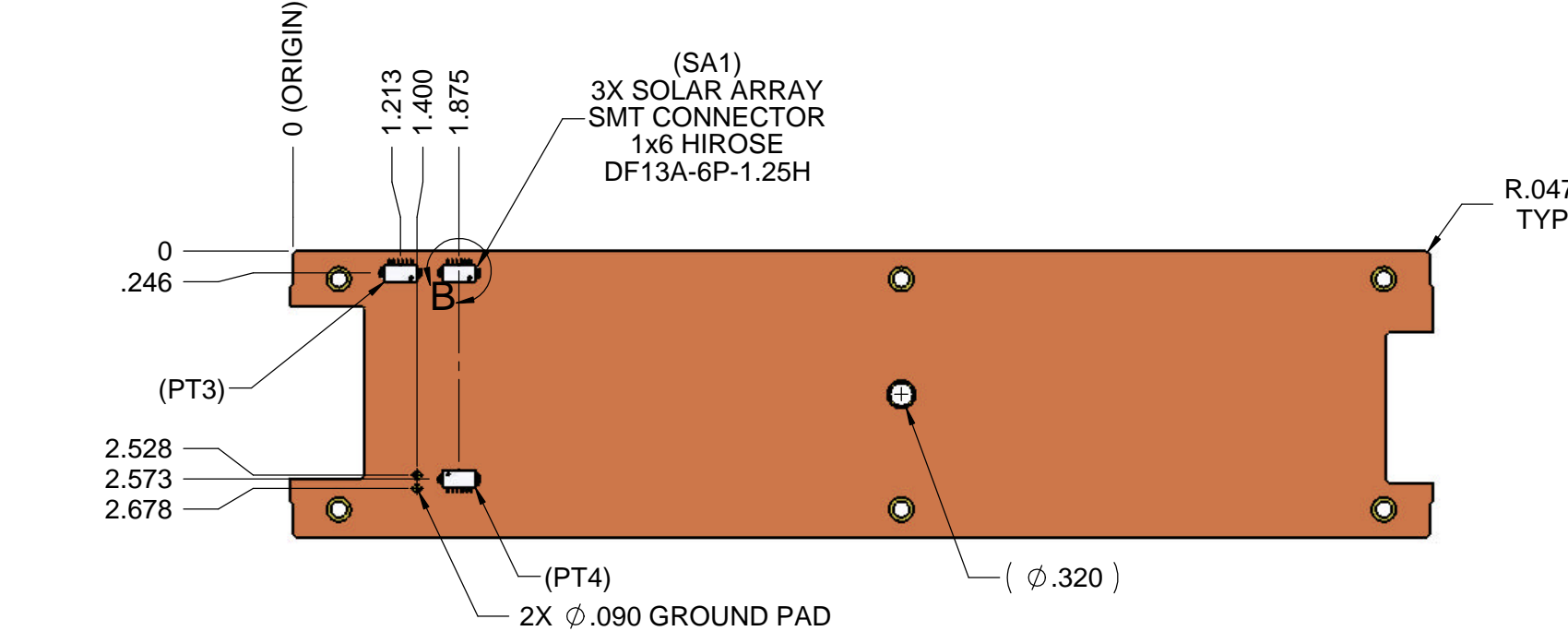
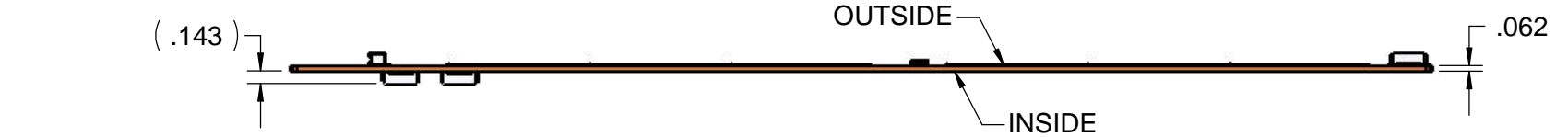

| | | | |
|---|----------------------|--|------------------------------------|
| MATERIAL: SEE NOTES | FINISH: SEE NOTES | HEAT TREAT: NONE | WEIGHT: |
| | | 750 Naples - San Francisco - CA 94112 (415) 584-6360 ph - (415) 585-7948 fax info@pumpkininc.com | |
| UNLESS OTHERWISE SPECIFIED DIMENSIONS ARE IN INCHES TOLERANCES ARE: | APPROVALS | DATE | TITLE |
| FRACTIONS DECIMALS ANGLES | DRAWN AWR | 11/07/08 | PCB, Front Panel Module, 3U |
| .X = ± .030 | CHECKED | | |
| .XX = ± .010 ± 0° 30" | QUAL ENG | | |
| .XXX = ± .005 | DO NOT SCALE DRAWING | SCALE 1 : 2 | REV B0 |
| CAD GENERATED DRAWING, DO NOT MANUALLY UPDATE | | | SHEET 1 OF 2 |

PROPRIETARY NOTICE

NOTICE IS HEREBY GIVEN THAT THIS DOCUMENT EMBODIES A CONFIDENTIAL PROPRIETARY DESIGN OR IS PART OF A CONFIDENTIAL PROPRIETARY DESIGN ORIGINATED BY OURSELVES OR ONE OF OUR CUSTOMERS, AND ALL DESIGN, MANUFACTURING, PREPRODUCTION USE AND SALE RIGHTS REGARDING THE SAME ARE EXPRESSLY RESERVED. IT IS SUBMITTED UNDER A CONFIDENTIAL RELATIONSHIP FOR A SPECIFIC PURPOSE, AND THE RECIPIENT BY ACCEPTING THIS DRAWING AGREES NOT TO SUPPLY OR DISCLOSE ANY INFORMATION REGARDING IT TO ANY UNAUTHORIZED PERSON, OR TO INCORPORATE IN OTHER PROJECTS, ANY SPECIAL FEATURES PECULIAR TO THIS DESIGN.

REVISION HISTORY

| REV | LOC | DESCRIPTION | DATE | APP'VD |
|-----|-----|-------------------------|------------|--------|
| B0 | | NO CHANGE TO THIS SHEET | 04/30/2009 | AWR |

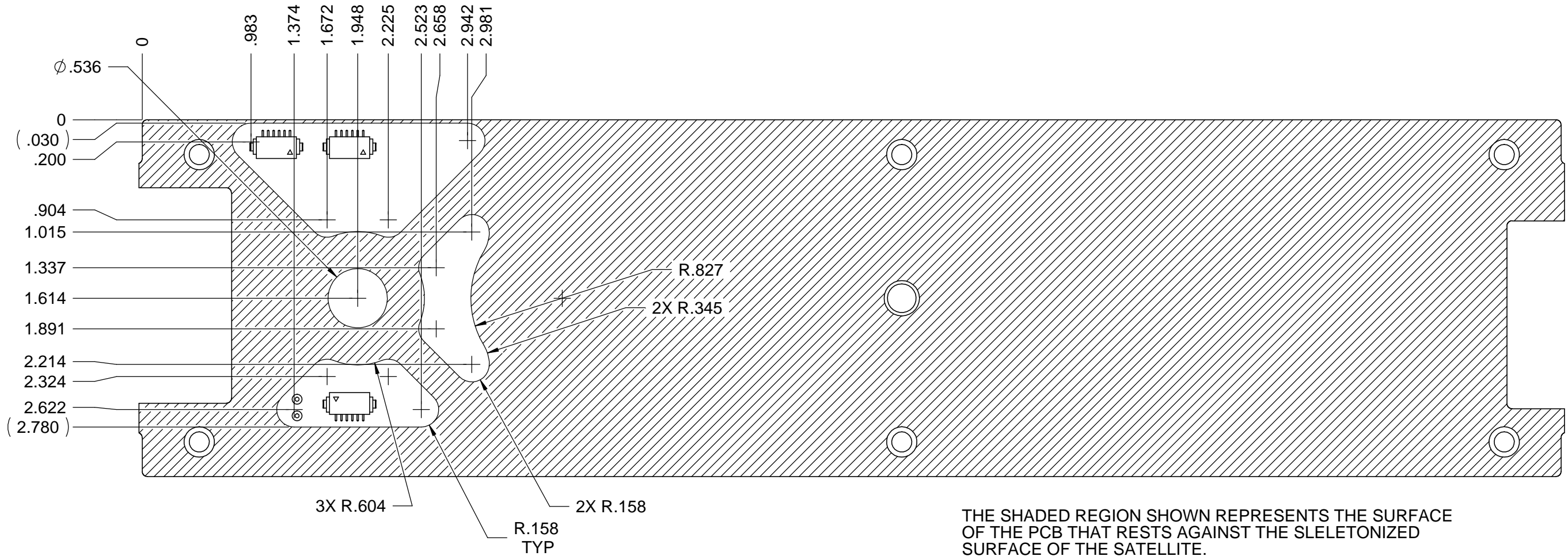

THE SHADED REGION SHOWN REPRESENTS THE SURFACE OF THE PCB THAT RESTS AGAINST THE SKELETONIZED SURFACE OF THE SATELLITE.

NOTES:

- 1) THIS IS A REFERENCE DRAWING TO ILLUSTRATE WHERE IT IS SAFE TO MOUNT COMPONENTS AND/OR RUN TRACES AND EXPOSED PADS ON THE BACKSIDE OF THE PCB.
- 2) ANY TRACES THAT EXIST IN THE SHADED AREA WILL NEED TO BE INSULATED WITH KAPTON TAPE, OR A SIMILAR INSULATING MATERIAL.
- 3) ZONES SHOWN ARE THE EXACT OVERLAY OF THE OPEN AREAS ON THE BUS CHASSIS *MINUS* a .030" RECOMMENDED TOLERANCE BUFFER.

| | | | |
|---|---|--|------------------------------------|
| MATERIAL: SEE NOTES | FINISH: SEE NOTES | HEAT TREAT: NONE | WEIGHT: |
|  | | 750 Naples - San Francisco - CA 94112 (415) 584-6360 ph - (415) 585-7948 fax info@pumpkininc.com | |
| UNLESS OTHERWISE SPECIFIED DIMENSIONS ARE IN INCHES TOLERANCES ARE: | APPROVALS | DATE | TITLE |
| FRACTIONS DECIMALS ANGLES | DRAWN AWR | 11/07/08 | PCB, Front Panel Module, 3U |
| .X = ± .030 | CHECKED | | |
| .XX = ± .010 ± 0° 30" | QUAL ENG | | |
| .XXX = ± .005 | CAD GENERATED DRAWING, DO NOT MANUALLY UPDATE | DO NOT SCALE DRAWING | SIZE B DWG. 705-00459 REV B0 |
| SCALE 1:1 | | SHEET 2 OF 2 | |